



RockFloor®

Thermal and acoustic stone wool insulation
for ground and separating floors.

The RockFloor® range comprises two product families; Thermal RockFloor® and Acoustic RockFloor®.

Thermal RockFloor is a dual-density insulation providing thermal performance for ground floors.

Acoustic RockFloor delivers impact sound protection for intermediate and separating floors (Report: BTC12397A).

- Minimises thermal and acoustic bridging.
- Absorbs sub-floor imperfections.
- Compatible with a wide range of installation methods.

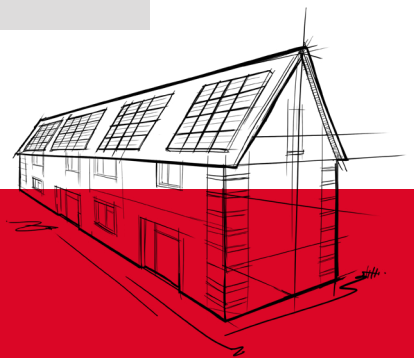

Stone wool is highly durable and long-lasting. Tests of ROCKWOOL stone wool recovered from old buildings have shown that our stone wool retains its performance characteristics – thermal, mechanical, fire resistance – for at least 50 years, and probably longer. A test of a 65-year-old stone wool sample found in 2023 during a renovation of Copenhagen airport showed that these characteristics had not diminished after 65 years.

Source: Testing done at Danish Technical Institute (DTI) in 2023, "Testing ROCKWOOL insulation from CPH airport hangar 4".



Figure 1 – Thermal RockFloor

APPLICATIONS

RockFloor is designed for use in thermal applications in ground floors, and for acoustic applications in intermediate and separating floors. This document details the different construction options available.

RockFloor

PERFORMANCE

Thermal performance

ROCKWOOL Thermal RockFloor has a thermal conductivity of 0.038 W/mK, in accordance with BS EN 13162:2012 + A1:2015.
 ROCKWOOL Acoustic RockFloor has a thermal conductivity of 0.040 W/mK, in accordance with BS EN 13162:2012 + A1:2015.

Thermal RockFloor

The U-value for ground floors is dependent upon size, shape, soil type, edge, insulation etc., therefore it is not possible to quote specific values. The following tables show the insulation thickness required to suit floor types based on their P/A ratio.

Construction 1: Ground bearing slab

Thermal RockFloor can be installed below the concrete slab or below screed.

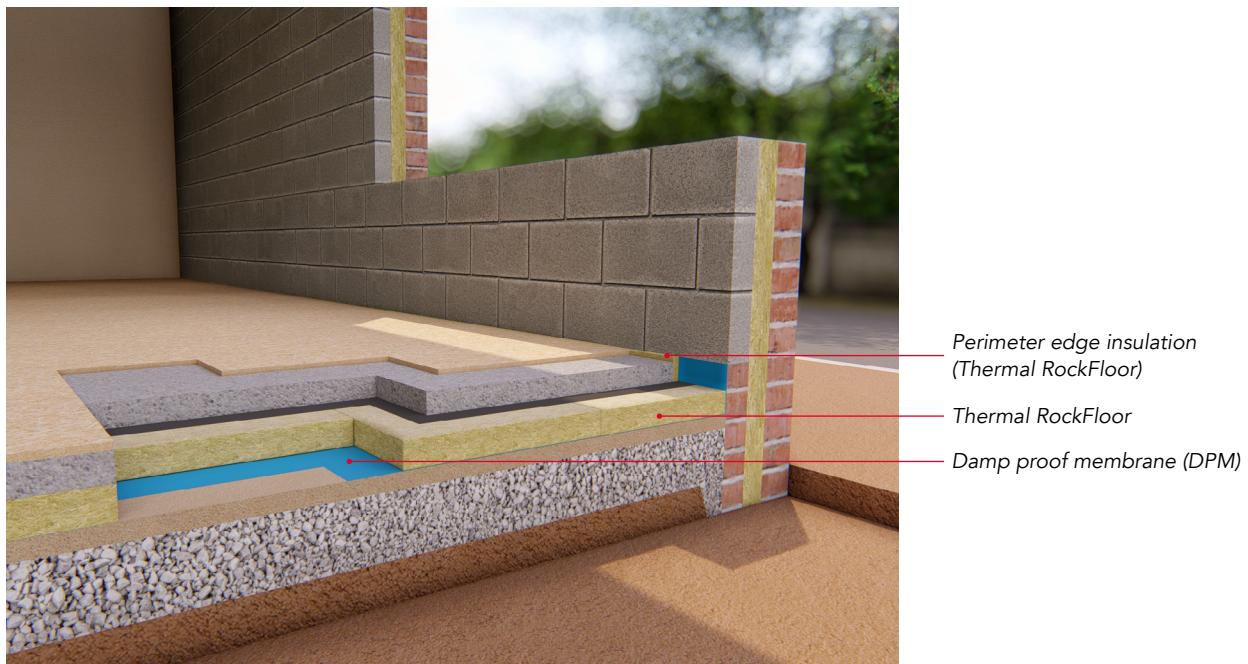

P/A ratio	U-value W/m ² K			
	0.25 Thickness (mm)	0.22 Thickness (mm)	0.20 Thickness (mm)	0.18 Thickness (mm)
0.1	nil	nil	nil	nil
0.2	30	50	65	90
0.3	60	80	95	120
0.4	75	95	110	130
0.5	85	105	120	140
0.6	90	110	130	150
0.7	95	115	130	150
0.8	105	120	140	160
0.9	105	125	140	160
1.0	110	130	145	175

RockFloor

Construction 2: Suspended beam and block

ROCKWOOL Thermal RockFloor is laid over the dense beam and block floor, below screed or tongue and groove flooring grade chipboard, where floor heights are limited.

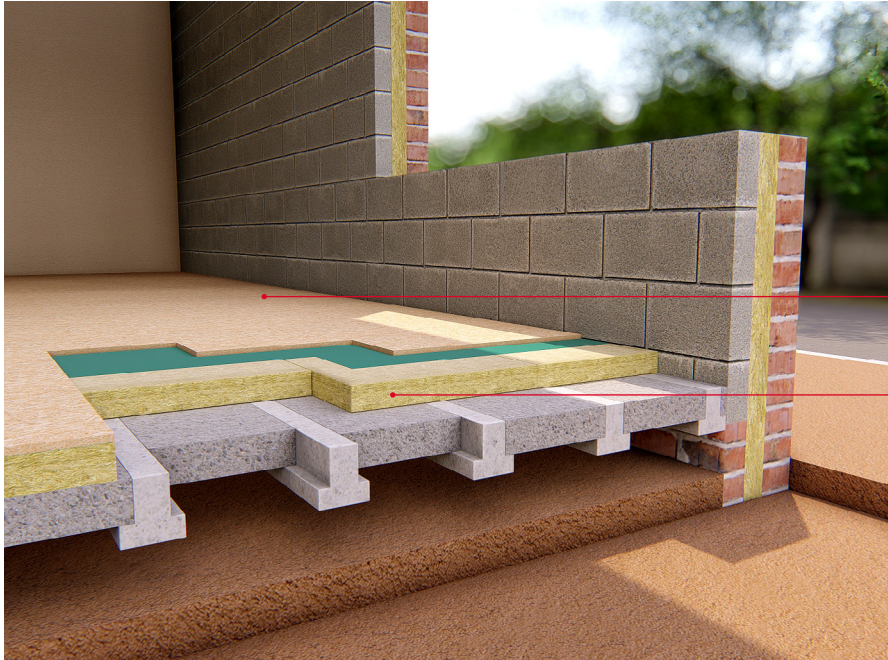

Tongue & groove chipboard finish
(or screed)

Thermal RockFloor laid over
500 gauge polythene vapour barrier —
when chipboard finish is used

P/A ratio	U-value W/m ² K			
	0.25 Thickness (mm)	0.22 Thickness (mm)	0.20 Thickness (mm)	0.18 Thickness (mm)
0.1	nil	30	50	70
0.2	65	80	100	120
0.3	80	100	120	140
0.4	95	115	130	150
0.5	100	120	135	160
0.6	105	125	140	160
0.7	105	130	145	165
0.8	110	130	145	165
0.9	115	130	150	170
1.0	115	135	150	170

These calculations are based on internal calculations carried out according to BS EN ISO 6946: 2017.

For further information on the declared performance characteristics, please refer to the product's [Declaration of Performance](#).

Fire performance

Thermal RockFloor and Acoustic RockFloor are able to resist temperatures of over 1,000°C, and achieve the highest Euroclass A1 non-combustibility classification as defined in EN 13501-1: 2018.

RockFloor

Acoustic performance

The non-directional fibre orientation and density of ROCKWOOL stone wool help absorb sound waves and dampen vibrations, contributing to a reduction in the transmission of noise.

Acoustic RockFloor

Separating floors

The Approved Document E describes a range of constructions that should achieve the standards if built correctly.

Service runs

Service runs can be accommodated by recessing the RockFloor and a minimum thickness of 50mm of insulation is required to achieve this.

Separating Timber Floor Upgrade (Material Change of Use): Approved Document E Section 4

Airbourne DnT,w + Ctr 43dB (or more).

Impact L'nT,w 64dB (or less).

- Floating layer: A minimum of two layers of board material are required to provide a minimum total mass of 25Kg/m², spot bonded together with joints staggered (eg 18mm tongue & groove flooring grade chipboard and 19mm plasterboard plank).
- The floating layer should be loose laid over the RockFloor.
- A minimum of 25mm of RockFloor resilient layer should be laid on the existing floor deck on existing timber floor joists.
- 100mm of ROCKWOOL Flexi® should be used between joists.
- Existing ceiling upgraded to 20Kg/m²: If the existing ceiling consists of lath and plaster, it should be retained, providing it satisfies Part B (Fire Safety). If in doubt, underdraw it with an additional layer of 12.5mm Firecheck board before screwing into the joists.
- Pre-completion site testing required.

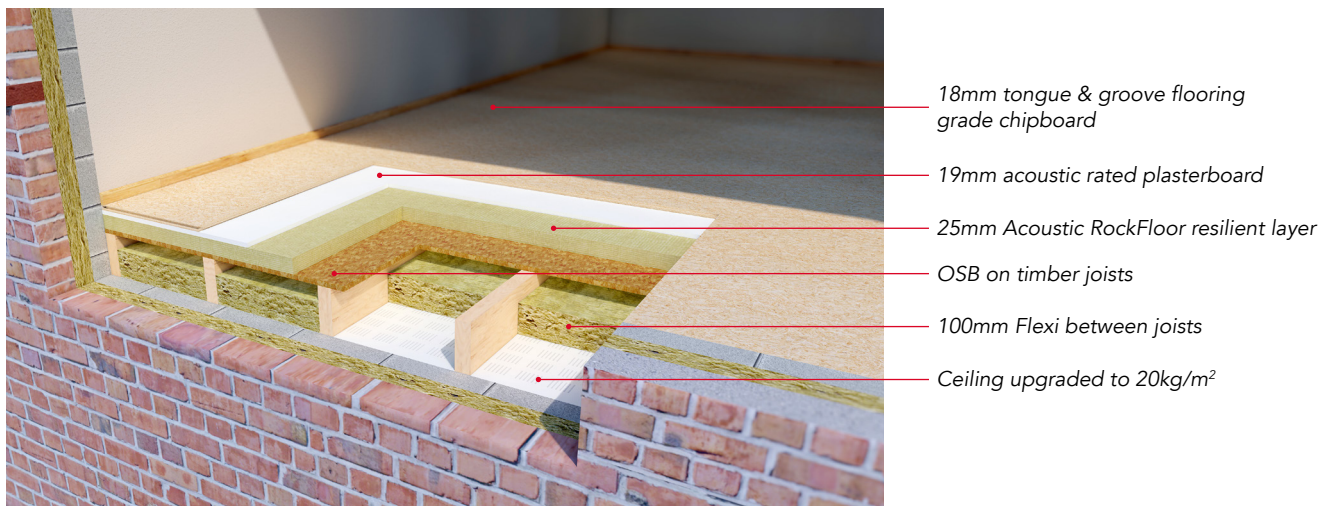

Note: If the existing ceiling is being replaced, the sound performance of the floor can be further enhanced by fitting resilient bars which isolate the ceiling from the floor structure.

By adopting this method, Site Test Report no. 2271 showed that the construction exceeded Approved Document E performance requirements:

- Airborne: Rw 48dB DnTw + Ctr.
- Impact: 58dB LnTw.

RockFloor

Robust details – Acoustic solutions

The Approved Document E includes references to Robust Details for use in new build separating wall and floor applications in dwellings. Compliance with the Robust Details will negate the requirement for pre-completion testing of new build separating wall and floor constructions.

Robust Details are based upon meeting sound test-values in excess of those required by Approved Document E.

This guide highlights Robust Details involving ROCKWOOL RockFloor products:

Separating floors – concrete

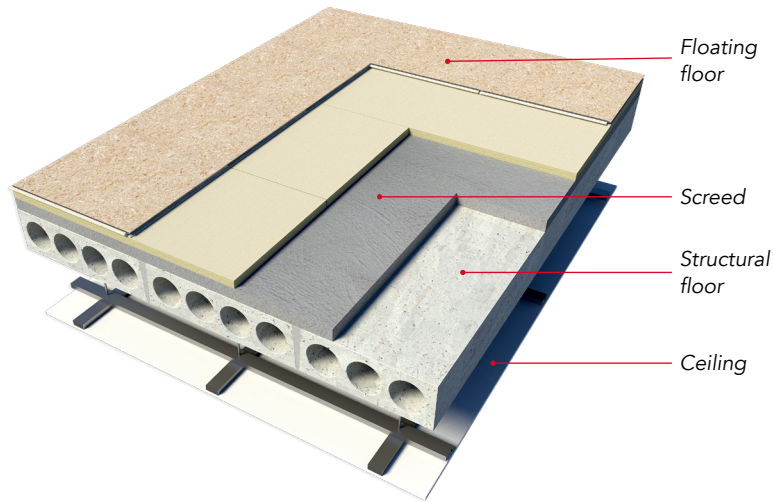

1. Pre-cast concrete plank – E-FC-1

Robust Details platform floor finish FFT4:

- Tongue & groove flooring board on 25mm ROCKWOOL RockFloor (shown).
- Screed: 40mm (min) screed nominal 80Kg/m² mass.
- Structural floor: 150mm (Min.) pre-cast concrete floor plank, minimum 300Kg/m² mass per unit area.
- Ceiling finish: See Robust Detail handbook for suitable ceiling options.

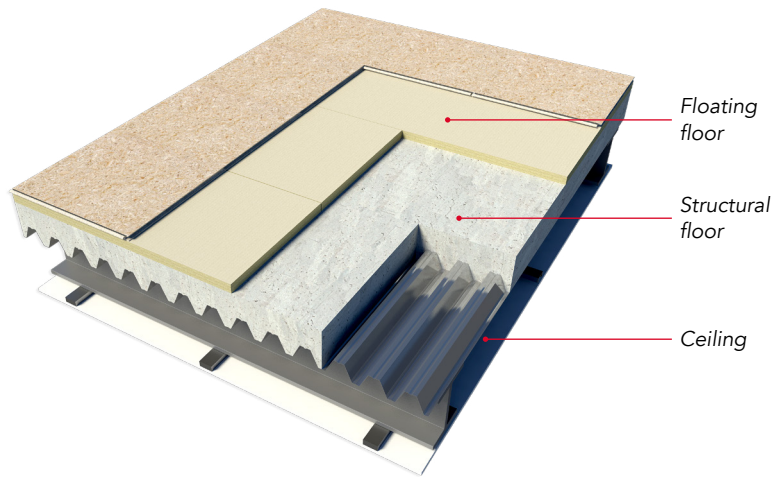

2. Steel-concrete composite – in-situ concrete slab supported by profiled metal deck E-FS-1

Robust Details platform floor finish FFT4:

- Tongue & groove flooring board on 30mm ROCKWOOL.
- Acoustic RockFloor.
- Structural floor: In-situ concrete slab, min density.
- 2200Kg/m³, supported by profiled metal decking.
- Concrete thickness: 80mm (Min.) at shallowest point and-130mm (Min.) at deepest point.
- Ceiling finish: See Robust Detail handbook for suitable ceiling options.

SPECIFICATION CLAUSES

The NBS clauses that include RockFloor can be found on NBS Source: source.thenbs.com

ADDITIONAL INFORMATION

Durability

Stone wool is highly durable and long-lasting. Tests of ROCKWOOL stone wool recovered from old buildings have shown that our stone wool retains its performance characteristics – thermal, mechanical, fire resistance – for at least 50 years, and probably longer. A test of a 65-year-old stone wool sample found in 2023 during a renovation of Copenhagen airport showed that these characteristics had not diminished after 65 years.

Source: *Testing done at Danish Technical Institute (DTI) in 2023, "Testing ROCKWOOL insulation from CPH airport hangar 4"*.

Condensation

ROCKWOOL stone wool insulation is vapour permeable, reducing the risk of condensation, which can lead to rot, mould, and humidity damage.

STANDARDS AND APPROVALS

Certificate

ROCKWOOL RockFloor products satisfy the requirements of EN 13162: 2012+A1: 2015 "Thermal insulation products for buildings. Factory made mineral wool (MW) products".

Manufactured under ISO 14001: 2015 Environmental Management Systems, and ISO 9001: 2015 Quality Management Systems.

PRODUCT INFORMATION

Product	Width (mm)	Length (mm)	Thickness (mm)
Acoustic RockFloor	600	1000	25 - 50
Thermal RockFloor	600	1000	50 - 185

LEGAL NOTICES

General safety requirements – Building Safety Act 2022

ROCKWOOL Limited is committed to supporting specifiers, resellers and users of ROCKWOOL products for the full life cycle of the product to comply with the obligations and responsibilities set out in the Building Safety Act 2022. With regard to the general safety requirements of the Act, ROCKWOOL Limited cannot control or foresee every situation where its products might be used. We therefore strongly advise that specifiers, resellers and users contact us where use of ROCKWOOL products is contemplated in applications different from those explicitly described in the latest, relevant ROCKWOOL product datasheets; especially in applications that can be reasonably foreseen as critical to safety.

ROCKWOOL Limited reserves the right to amend the specification of its products without notice. Changes to the ROCKWOOL manufacturing process, or to pertinent regulations, may be reflected in changes to tested and certified product performance. Whilst ROCKWOOL Limited endeavours to keep its publications up to date, readers will appreciate that between publications there may be pertinent changes in the law or other developments affecting the accuracy of the information contained in our publications.

ROCKWOOL Limited does not accept responsibility for the consequences of using (including testing or certifying) its products in applications different from those explicitly described in the relevant ROCKWOOL product datasheets. Expert advice should be sought, and ROCKWOOL Limited should be contacted, where such different use is contemplated, or where the extent of any use described by ROCKWOOL Limited is in doubt.

The ROCKWOOL Trademark

ROCKWOOL® - our trademark

The ROCKWOOL trademark was initially registered in Denmark as a logo mark back in 1936. In 1937, it was accompanied with a word mark registration; a registration which is now extended to more than 60 countries around the world.

The ROCKWOOL trademark is one of the most important assets of the ROCKWOOL Group, and is therefore well-protected and defended by ROCKWOOL throughout the world.

If you require permission to use the ROCKWOOL logo for your business, advertising or promotion, you must apply for a Trade Mark Usage Agreement.

To apply, write to:
marketcom@rockwool.com

Trademarks

Registered trademarks of the ROCKWOOL Group include but are not limited to:

ROCKWOOL®, RockClose®, RainScreen Duo Slab®, HardRock®, RockFloor®, Flexi®, RockFall®, FirePro®, DuctRock®, BeamClad®, NyRock®

© ROCKWOOL 2026.
All rights reserved.

Health and safety

A Material Safety Data Sheet is available and can be downloaded from rockwool.com/uk to assist in the preparation of risk assessments, as required by the Control of Substances Hazardous to Health Regulations (COSHH).

Photography and illustrations

The product illustrations are the property of ROCKWOOL Limited and have been created for indicative purposes only.

Unless indicated below, the photography and illustrations used in this guide are the property of ROCKWOOL Limited. We reserve all rights to the usage of these images.

If you require permission to use ROCKWOOL images, you must apply for a Usage Agreement.

To apply, write to:
marketcom@rockwool.com

Company:	ROCKWOOL Limited
Version:	Version 2.03 March 2026 <i>(to check this is the latest version, please refer to rockwool.com/uk)</i>
Revised on:	11.03.2026
Product name:	RockFloor®
Replaces version:	Version 2.02 November 2025
Changes made:	<ul style="list-style-type: none"> • Updated product information • Updated testing information • Updated performance information
Additional information:	N/A

Please ensure you are using the latest version of this document by verifying it on our official website. Do not rely on printed or previously downloaded copies, as these may be out of date.

Please contact the ROCKWOOL Technical Support Team if you would like to access archived versions of this document.

ROCKWOOL stone wool – safe to install and live alongside

There are no hazardous classifications associated with stone wool insulation manufactured by ROCKWOOL UK according to EU REACH and UK REACH regulations on health and the environment.

ROCKWOOL safe use instruction sheets and material safety data sheets (where applicable) can be downloaded [here](#).



Sustainability

ROCKWOOL products are used to help enrich modern living, supporting more resilient and comfortable buildings.

We transform abundant, natural volcanic rock into stone wool insulation products that help our customers tackle energy consumption, noise pollution, fire resilience, and climate change challenges such as water scarcity and flooding.

Since our stone wool is endlessly recyclable with no loss in its performance properties, we can take back clean, uncontaminated new off-cuts and unused ROCKWOOL stone wool insulation from construction sites in the UK. Our service, Rockcycle®, takes back our stone wool and recycles it back into production where it is used to make new ROCKWOOL products.

Our annual sustainability reports, which set out progress against our sustainability goals, and further details of the positive impacts of using our products can be found on our website.

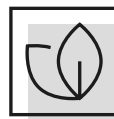

Environment

ROCKWOOL takes a fact-based, auditable approach to documenting our progress in maximising our products' positive impact and minimising the effect our operations have on the environment, backed by third-party references and methodologies. Further details can be found online in our annual sustainability report.

Our high-tech production process uses filters, pre-heaters, after-burners and other cleaning and collection systems that help to reduce the effects of our manufacturing operations on the environment.

ROCKWOOL stone wool insulation does not contain (and has never contained) gases that have ozone depletion potential (ODP) or global warming potential (GWP).

